

Portable Single Barrel, Air Operated Piston Filler

Low Cost, Accurate, Durable,
Flexible and Reliable

- The entire frame and product contact system, including hopper, barrel, switching valve and tube end are constructed of 304 stainless steel
- Five minute changeover time
- Fill accuracies maintained to one-half of one percent
- Infinitely variable speed control from one to thirty cycles per minute
- Barrels available to handle from fractional ounce fills up to five quart capacity
- Positive shut off fill tube insures drip-free filling
- Computer machined parts

A Standard
Approach to
Special
Problems

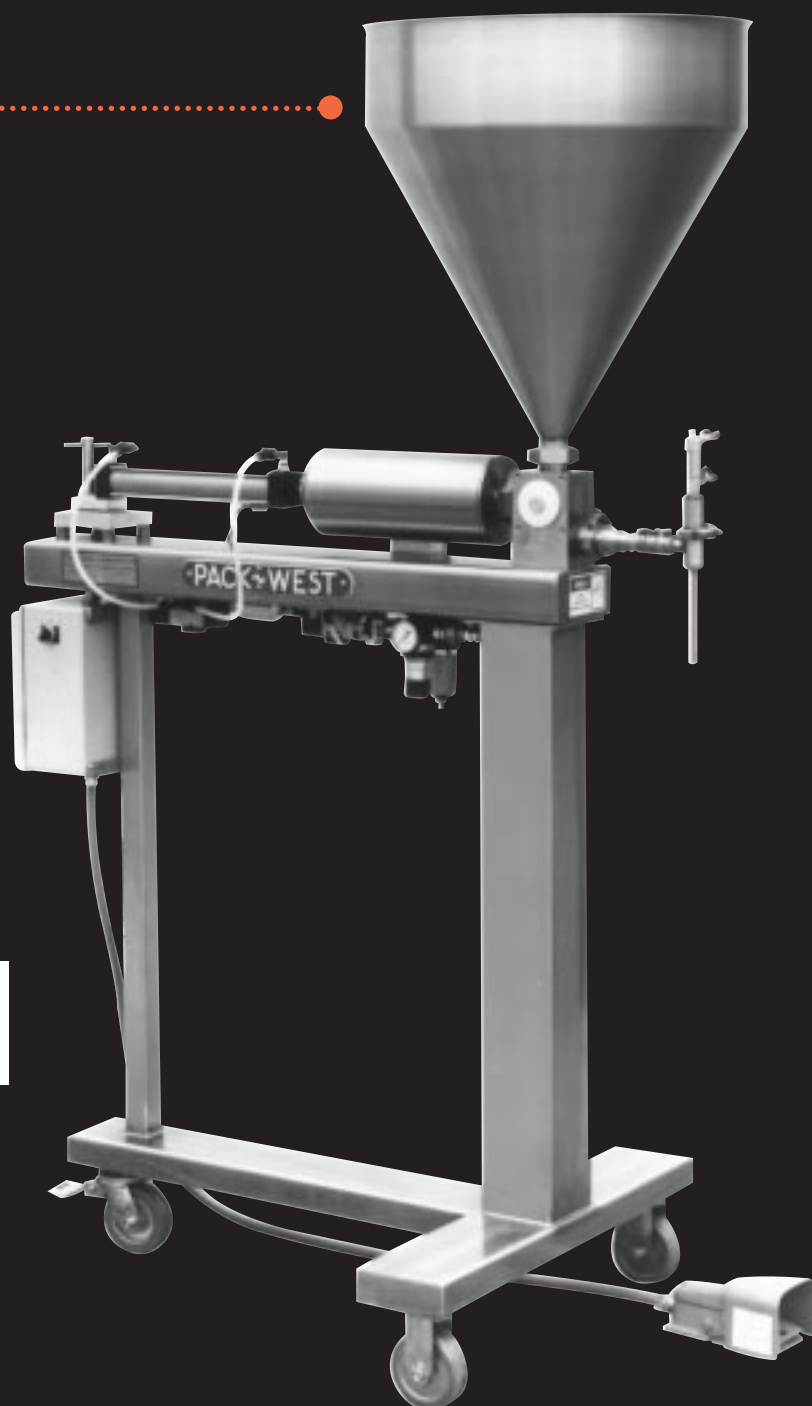

**PACK
WEST**
Precision Packaging Systems

Features and Specifications



Member of
WESTERN
PACKAGING
ASSOCIATION

- Handles water thin products, creams and even salsa type products from sub-ambient temperatures up to 200°F
- Available in bench mount versions
- Easy to operate and maintain
- Foot pedal operation for continuous or intermittent operation
- Temperature controlled housings are available
- Twenty-five gallon working capacity hopper
- Sanitary quick disconnect clamps are used on all product contact parts meaning no tool dismantlement
- Fast set up — logable changeover
- Custom engineered fill tubes for any filling requirement
- 304 stainless steel is standard, but higher grades are available
- Product level control systems are available
- Heavy gauge stainless steel frame
- Air filter, regulator and oiler supplied with each machine
- Versatile — capable of filling glass, tin, plastic, tubes, pails, pouches, bag-in-box, etc.

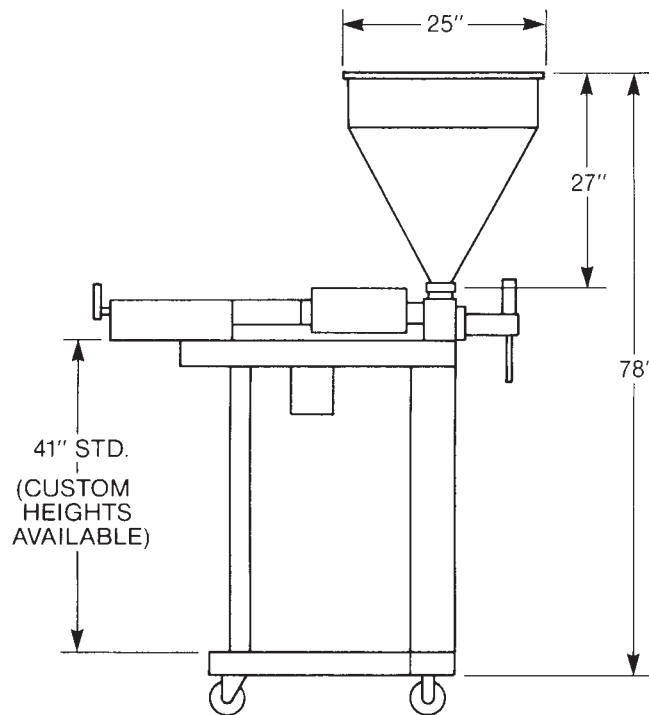

Elevation View

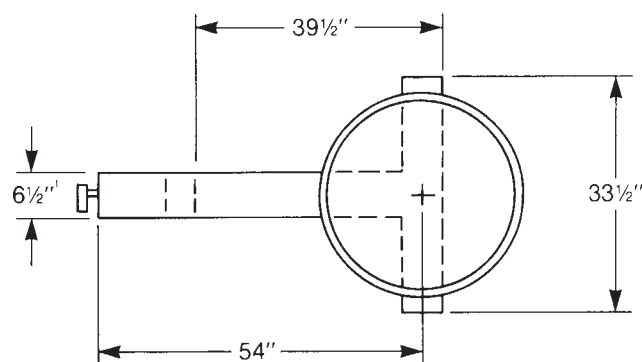

Floor Plan

4505 Little John Street,
Baldwin Park, California 91706
Phone: 626-814-4766
Fax: 626-814-1615
www.packwest.com

